

PRESSURE CONTROL VALVE MODEL : PCV

Description

Pressure control valves are direct operated hydraulically cushioned valves. These are used to control sequencing, unloading or back pressure of oil flow in a hydraulic system. The control can be initiated by sensing the pressure rise internally (directly from it's inlet port A) or remotely (from it's remote pressure control port X). The valves with auxilliary pilot pressure port P(Model PCV20E/F/G/H) can be actuated by lower remote pressure than that is required at normal remote pressure control port.



Section

Hydraulic Symbol

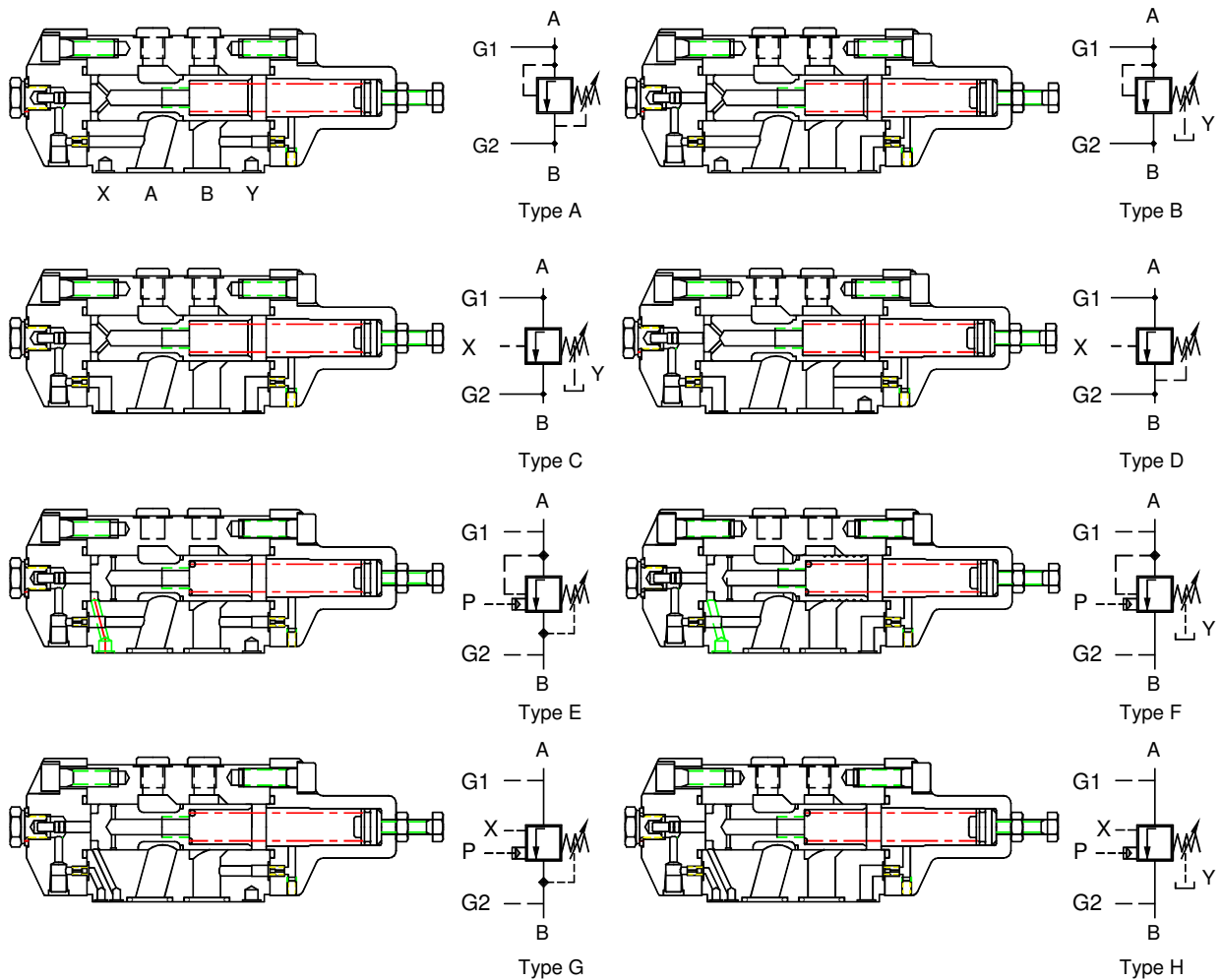

PRESSURE CONTROL VALVE MODEL : PCV

Unit Dimensions

Dimensions in mm.

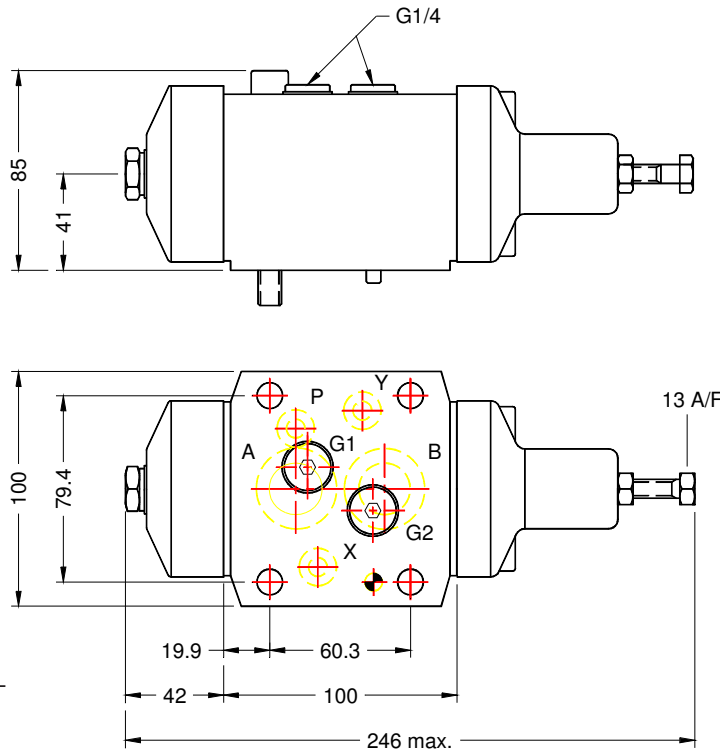
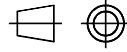

Valve fixing screws M10x90L

Technical Specifications

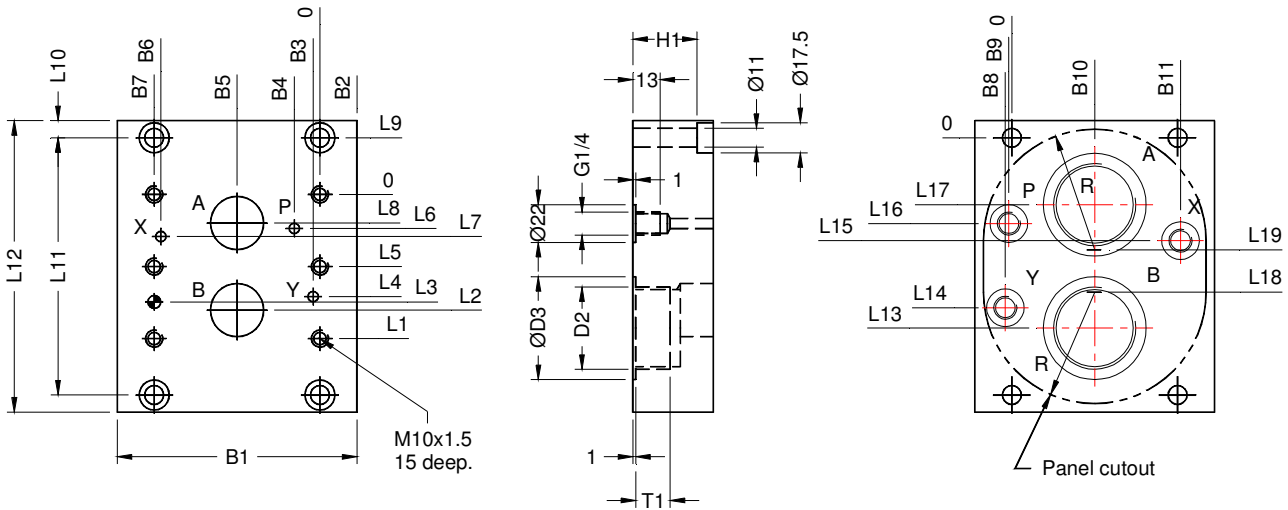

Size	Model	Ma- ss kg	B1	-B2	B3	B4	B5	B6	B7	B8	B9	B10	B11	D1	D2	D3	H1	H2	L1	L2
20	PCV20G04	5.2	112	16.3	6.4	14	39.7	73	79.4	3	3	39.7	75	22	G3/ 4	36	25	45	60.3	49.2
	PCV20G05	5.2	112	16.3	6.4	14	39.7	73	79.4	3	3	39.7	75	22	G1	44	25	45	60.3	49.2

Size	Model	L3	L4	L5	L6	L7	L8	-L9	L10	L11	L12	L13	L14	L15	L16	L17	L18	L19	R	T1
20	PCV20G04	44.5	11.1	-	39.7	20.8	11.1	22	16	104	136	77	39	42.6	64	27	57	47	52	16
	PCV20G05	44.5	11.1	-	39.7	20.8	11.1	22	16	104	136	82	39	42.6	64	22	57	47	52	18

PRESSURE CONTROL VALVE MODEL : PCV

Technical Specifications

Construction	Direct actuated spool type with hydraulic cushioning.
Mounting	Subplate mounting
Mounting position	Optional.
Direction of flow	Port A to port B.
Maximum working pressure	For valves with internal drain A, X & P 350 bar. B Atmospheric pressure.
Pilot pressure required at auxilliary remote control port P	Min. 12% of the se pressure for valve, with operating pressure 100 or 50 bar. Min. 7% of set pressure for valve with operating pressure 160 bar.
Fluid temperature range	-10 c to + 80 c
Viscosity range	10 cSt to 380 cSt.
Fluid cleanliness requirement	As per ISO 16 / 13
Flow handling capacity.	160 l / min.
Mass	7.5 kg.

Ordering Code

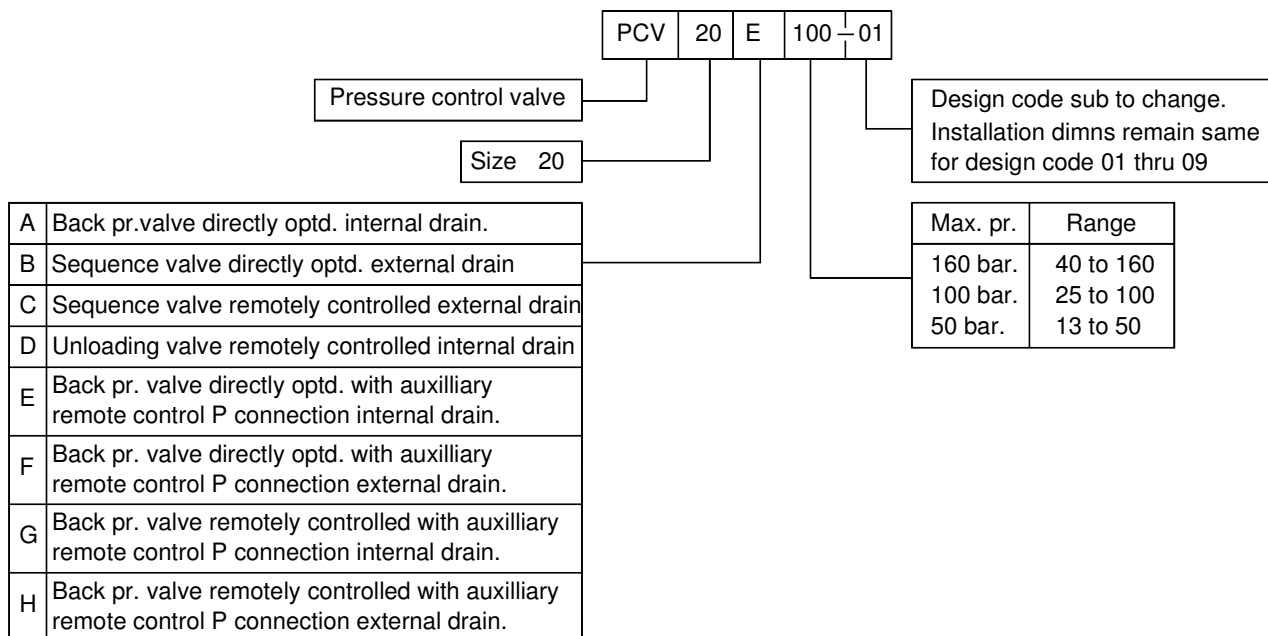

PRESSURE CONTROL VALVE MODEL : PCV

All rights reserved
subject to revision.

PRISM HYDRAULICS PVT. LTD.
B-23 Angol Indl.Estate,
Udyambag,
Belgaum - 590 008. INDIA.

Phone :- +91-(0831)-2443448
Fax :- +91-(0831)-4202340
E-mail :- prismhydraulics@gmail.com